

# LE PRO LED Shoe Box Light Instruction

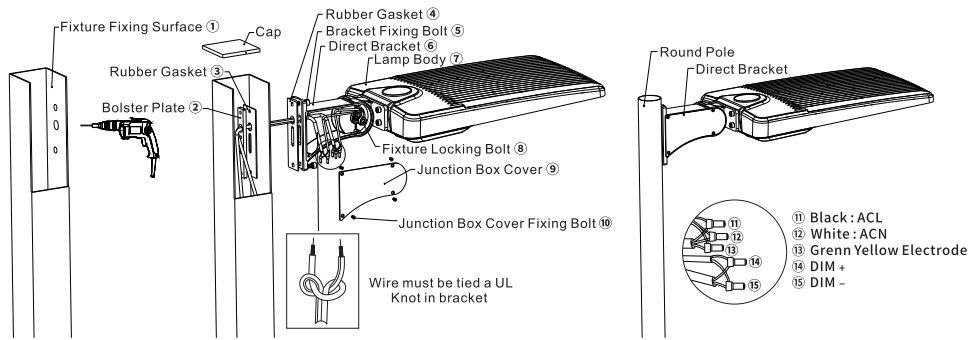

## Installation IV:

1. Use electric drill to drill holes on the required fixture surface, the hole pitch should match the trunnion bracket's ⑥.
2. Put the trunnion bracket against to the required fixture surface, and tighten bolt ②.
3. Let the wire go through the pole and trunnion bracket by matched hole, Connect the power wire to pole wire and make sure the good protection on the wire connection. Protecting the wire from damage and note the polarity.
4. Loosen bolt ③ and bolt ①, adjust lamp body ⑤ to required angle, and then tighten bolt.
5. Fixing the pole cap if it has.

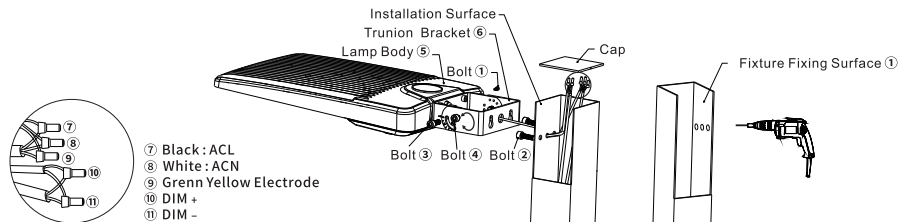

## Notice:

LED shoebox light can be equipped with dimming, photocell sensor, and microwave sensor as required.

## Warning/Arertissement:

MIN90°C SUPPLY CONDUCTOR

THIS PRODUCT MUST BE INSTALLED IN ACCORDANCE WITH THE APPLICABLE INSTALLATION CODE BY A PERSON FAMILIAR WITH THE CONSTRUCTION AND OPERATION OF THE PRODUCT AND THE HAZARDS INVOLVED.

LES FILS D' ALIMENTATION 90 °C MIN

CE PRODUIT DOIT ETRE INSTALLE SELON LE CODE D' INSTALLATION PERTINENT, FONCTIONNEMENT AINSI QUE LES PISQUES INHERETS.

## Cautions:

1. To avoid electric shock and fire, the lights must be installed by a person with professional knowledge of luminaires electrical systems or a qualified electrician.
2. Please wear protective gloves to avoid injury before install this lights.
3. During or after installation, if there are any signs of smoke, fire in wires or lights, please turn off all power immediately and notify relevant personnel of an overhaul.
4. This light can be used for indoor and outdoor installation.

## Warning:

1. Please abide to related country, regional, and local laws and regulations when install this lights.
2. To avoid electrical shock and damage, please do not install this lights on raining days or exist any potential safety hazards.
3. Can not use unstable voltage facility (eg: electrical generator etc.) to test this led lights.

## Wiring Diagram:

The wire color for DIM+ AND DIM-, please in kind prevail.

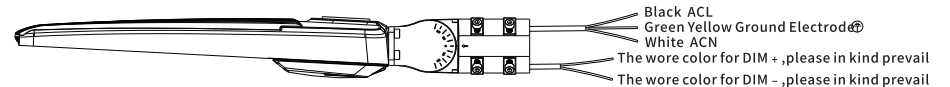

## Brackets Options:

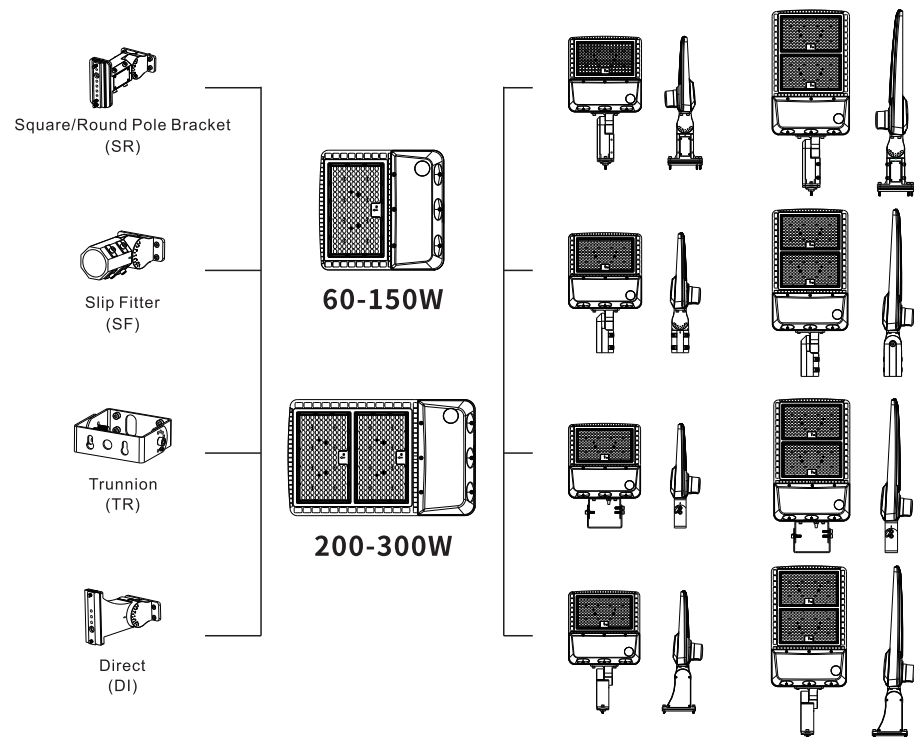

## Installation I :

### Installation 1.1:

- (1) Detach adapter plate ⑩ and rubber gasket ⑪ from bracket.
- (2) Make sure the square pole or fixture surface has matched installation holes.
- (3) Let the wire go through the hole and square/round pole bracket ③, protecting the wire from damage.
- (4) Put square/round pole bracket ③ against to the required fixture surface, rubber gasket ⑥ between the square/round pole bracket ③ and required fixture surface, then fix square/round pole bracket ③ to the square pole with bolt ②.
- (5) Fix the bolster plate ⑨ to inside surface of the square pole if necessary, then tighten the bolster plate ⑨ with bolt ②.
- (6) Connect the power wire to the pole wire and make sure the good protection on the wire connection, then fix rubber gasket ⑧ and junction box cover ⑦ with bolt ⑫.
- (7) Adjusting the lamp body ① to required angle, then tighten with bolt.

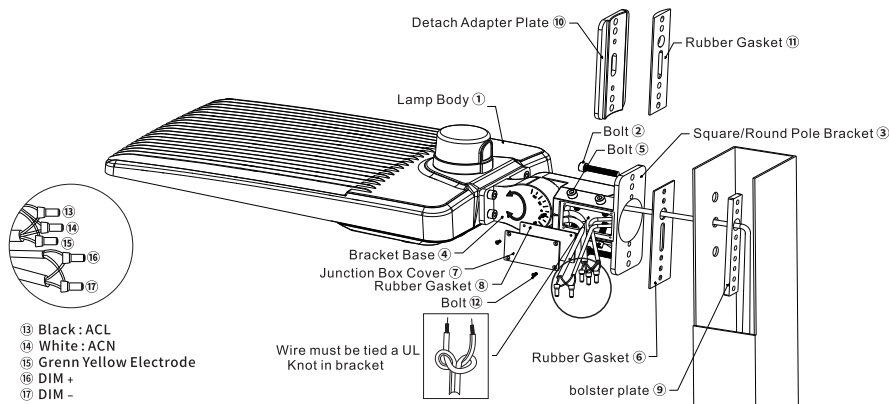

### Installation 1.2:

- (1) Make sure the round pole has matched installation holes.
- (2) Let the wire go through the hole and square/round pole bracket ③, protecting the wire from damage.
- (3) Fix the bolster plate ④ to inside surface of the round pole with bolt ③.
- (4) Connect the power wire to the pole wire and make sure the good protection on the wire connection, then fix junction box cover ⑥ with bolt ⑤.
- (5) Adjusting the lamp body to required angle, then tighten with bolt.

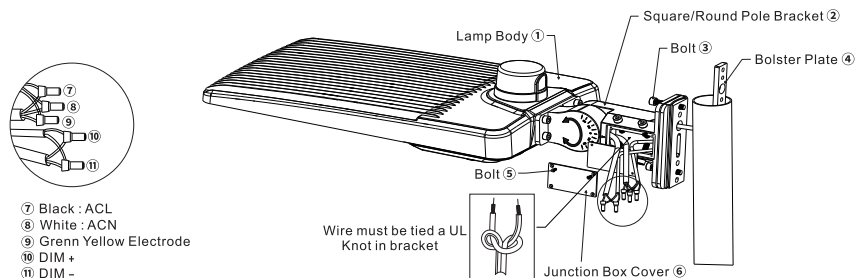

2

### Installation 1.3:

- (1) Connect the power wire to the pole wire and make sure the good protection on the wire connection, then put the wire connection into the square/round bracket. Protecting the wire from damage.
- (2) Loosen the bolt ③, put the round pole into square/round pole bracket ②, then fasten the bolt ③.
- (3) Adjusting the lamp body to required angle, then tighten with bolt.

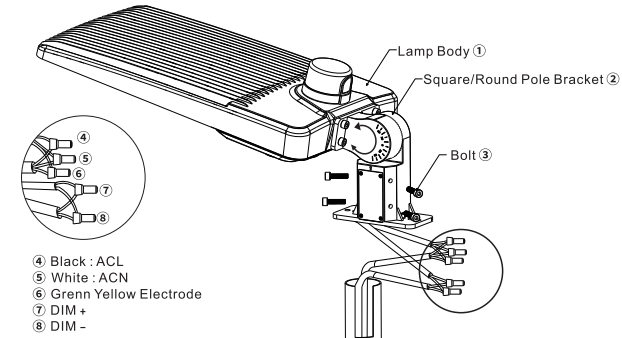

### Installation II :

1. Connect the wire correctly between the fixture and the pole, then put the wire into pole. Pay attention to the polarity of the wire.
2. Loosen the pole locking bolts ②, put the slip fitter bracket ④ into pole, then fasten the pole locking bolts ②. Please pay attention to protecting the wire from damage when installing this lamp body.
3. Loosen the adjusting bolts ③, adjusting the lamp body ① to required angle, then tighten adjusting bolts ③.

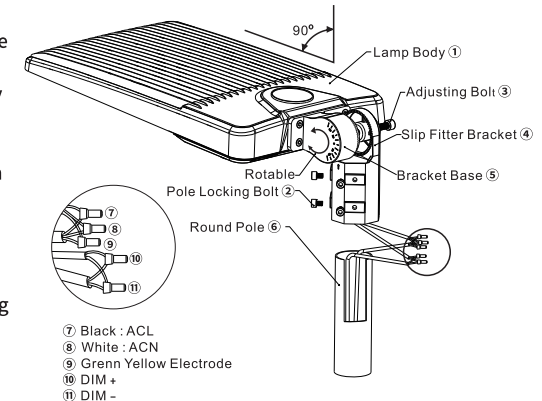

### Installation III :

1. Use electric drill to drill holes on the required fixture surface, the hole pitch should match the direct bracket ⑥.
2. Install the bolster plate ② and rubber gasket ③ at the inside surface of the square pole, then fix the direct bracket to the square pole, tighten with bracket fixing bolt ⑤, bolster plate ② and rubber gasket ④.
3. Let the wire go through the pole and direct bracket by matched hole. Connect the power wire to pole wire and make sure the good protection on the wire connection. Then put the wire connection into the direct bracket.
4. Loosen fixture locking bolt ⑧, adjust lamp body ⑦ to required angle, and then tighten bolt.
5. Fixing junction box cover ⑨ and tighten it with bolt ⑩.
6. Fixing the pole cap.
7. The above installation steps can also be applied to round pole.

3